

Powers
FASTENERS

Distributed by:

Aerofast Australia Pty Ltd

ABN: 23 068 361 455

LOGAN CITY

8 Booran Drive, Woodridge QLD 4114

Tel: 07 3299 4555 Fax: 07 3299 4566

email: sales@aerofast.com.au

GOLD COAST

Unit 1/13 John Duncan Court

Varsity Lakes QLD 4227

Tel: 07 5593 4550 Fax: 07 5593 4549

email: coastsales@aerofast.com.au

WEB: www.aerofast.com.au

Blue-Tip SCREW-BOLT™



Powers offers the widest range of mechanical and adhesive fasteners in the market place.

Powers products cover the full traditional anchoring range while specializing in innovative products that provide the architect, engineer and end user with aesthetic, high performance, labour saving fastening solutions.

Fast technical advice, free samples and free on site demonstrations. Call toll free 1800 677 872 or visit our web site www.powers.com.au

Major Project Specifications

Support



Federation Square
Melbourne



In House Product
Training Facility
Melbourne

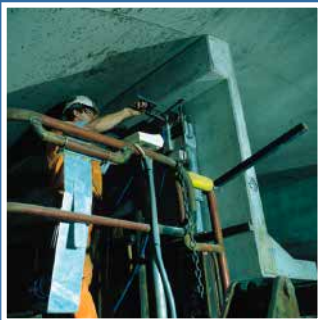

Burnley and
Domain Tunnels
City Link Project
Melbourne



In House Product &
Application Testing
Service
Melbourne



Sydney Airport
Rail Link



National on Site
Anchor Testing
Service



Workcover
Recommended Safety
Anchors



National On Site
Service
Powers Training
Vehicles (PTV)

Contents

| | |
|--|----|
| Introduction - | |
| The NEW Powers Blue -Tip SCREW-BOLT™ | 4 |
| Key features | 5 |
| Product description | 6 |
| Installation procedure | 10 |
| Anchor sizes | 11 |
| Mechanical properties | 11 |
| Installation specifications | 12 |
| Material specifications | 12 |
| Anchor design concepts | 13 |
| Performance data | 13 |
| Design criteria - concrete | 15 |
| masonry | 16 |
| Anchors for use in seismic/cyclic applications | 17 |
| Product specification writing | 17 |

The NEW Blue -Tip SCREW-BOLT™

Powers Fasteners' goal is to provide the industry with the best innovative fastening systems for concrete and masonry base materials. Powers Fasteners' reputation for providing problem solving anchoring solutions is again further enhanced with the release of the New Improved Blue -Tip SCREW-BOLT™.

The industry acceptance of the Excalibur SCREW-BOLT™ anchor has created a significant shift away from conventional anchoring methods, and now with the release of the new improved Blue -Tip SCREW-BOLT™, wider market growth and penetration is forecast over traditional mechanical expansion and adhesive anchors.

Why Blue -Tip SCREW-BOLT™?

- Blue -Tip SCREW-BOLT™ is user friendly and can be installed quickly.
- Blue -Tip SCREW-BOLT™ out performs all equivalent bolt size traditional anchoring systems.
- Blue -Tip SCREW-BOLT™ is easily removable and can be re-installed.
- Blue -Tip SCREW-BOLT™ is universal and will work in Brick, Concrete and Block-work.
- Blue -Tip SCREW-BOLT™ is more aesthetically pleasing in situ.
- Blue -Tip SCREW-BOLT™ can be loaded immediately unlike adhesive anchors that require a curing time.
- Blue -Tip SCREW-BOLT™ is ideal for anchoring applications close to the edge of concrete slabs.

This manual has been designed as a resource guide to provide both the designer and contractor with the latest installation and performance information that include; -

- Limit state design data
- Working stress design data
- Performance data in different types of Australian made bricks
- Benefits compared to mechanical expansion anchors
- Benefits compared to adhesive anchors
- Design parameters, edge distance, spacing and combined loading data
- Simple, clear and detailed product information

Whether you are a designer or contractor the Blue -Tip SCREW-BOLT™ will answer most of your concrete and masonry fastening needs.

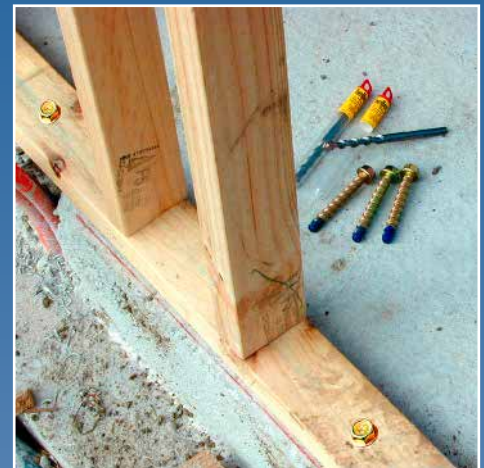

KEY FEATURES



One-Piece Design

Matches Standard Fixture Holes

Works In Most Base Materials

Matched Tolerance System

Shallow Embedment Depth

Low Installation Torque

Close To Edge Installation

Fast, Easy, High Speed Installation

Won't Spin in the Hole

Safe, Controlled Installation Method

Immediate, High Strength Loading

Finished Appearance

Easy to Read Length Identification

Removable and Reusable

Vibration Resistant

High Strength

Cost Effective

If you would like a demonstration of the Blue -Tip SCREW-BOLT™ or further details on the range, or any of the other innovative fastening systems from Powers Fasteners, please contact your closest Powers Fasteners branch or alternatively request information via our Web site at www.powers.com.au

Product description

Blue -Tip SCREW-BOLT™ anchors have many unique features and benefits that make this innovative anchor well suited for almost every application. Optimum performance is obtained using a combination of patented design concepts. The benefit to the designer is higher load capacities while the benefit to the user is easy and fast installation. Let's take a look at how this remarkable product works.

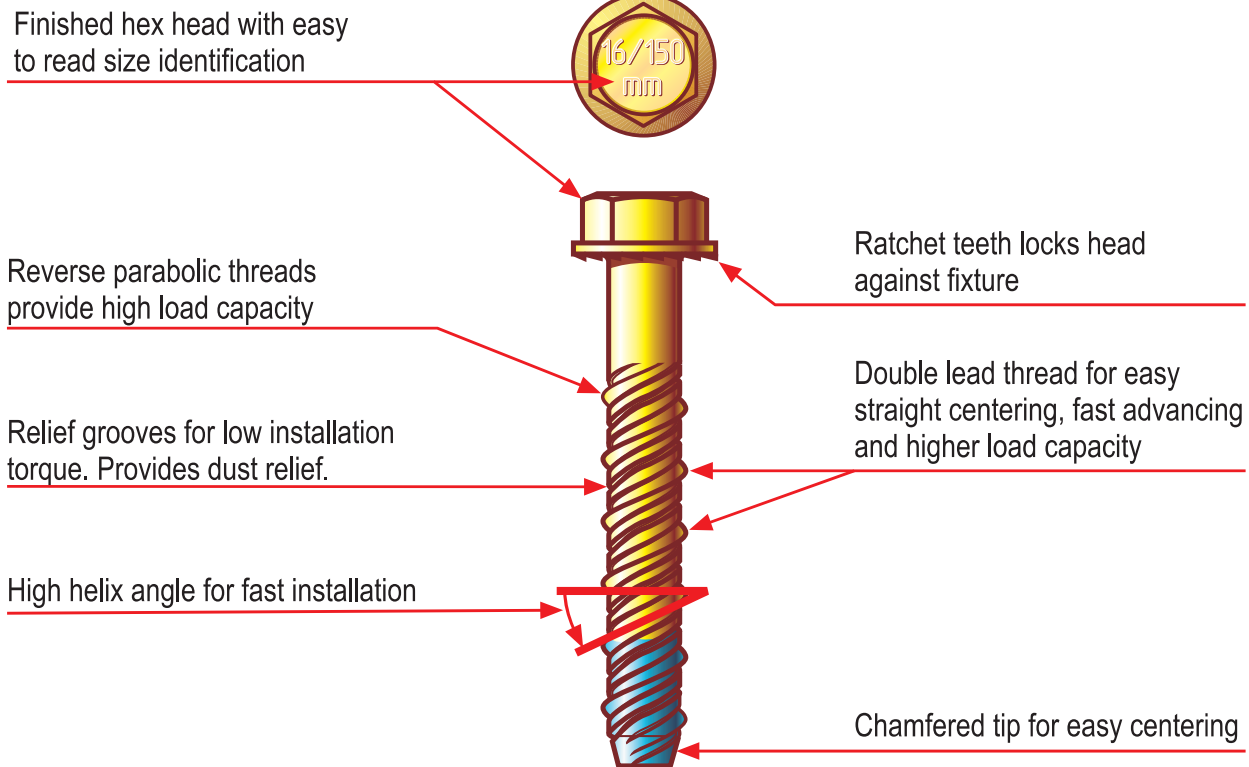

One piece design

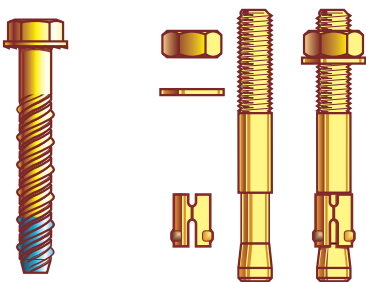

Blue -Tip SCREW-BOLT™ anchors are one-piece units featuring a finished hex head formed with an integral washer, a patented dual lead thread, and a chamfered tip. A one-piece design eliminates the possibility of lost anchor parts or improper assembly.

Matches standard fixture holes

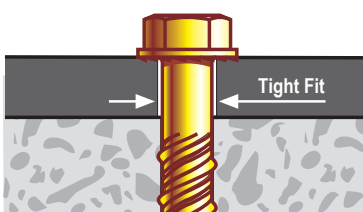

Blue -Tip SCREW-BOLT™ anchors are designed to match standard fixture holes that are 2mm over nominal to provide a secure fit. Since the Blue -Tip SCREW-BOLT™ is specifically matched to the clearance hole, the need for hole layout is eliminated.

Works in most base materials

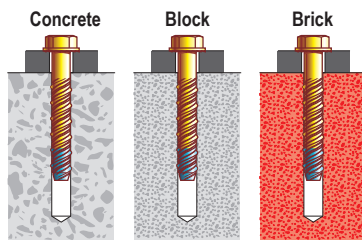

Blue -Tip SCREW-BOLT™ anchors are versatile and can be used in a variety of base materials. This eliminates the need to stock assorted anchor types and learn a variety of installation procedures.

Shallow embedment depth

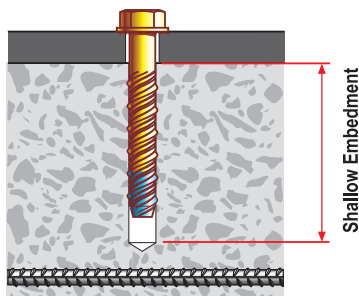

Blue -Tip SCREW-BOLT™ anchors can be installed at a shallower embedment than traditional wedge or sleeve anchors reducing the chance of striking reinforcing bars or embedded cables. Drilling size, depth and time can be reduced resulting in significant cost savings.

Close to edge installation

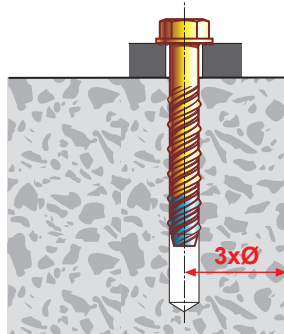

Blue -Tip SCREW-BOLT™ anchors cut a thread into the base material. Since there are no expansion forces, the Blue -Tip SCREW-BOLT™ anchor can be installed closer to the edge than traditional mechanical anchors without damaging the base material.

Fast, easy, high speed installation

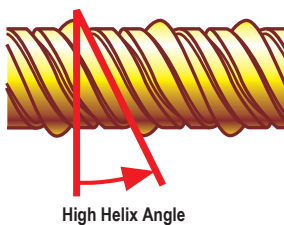

Blue -Tip SCREW-BOLT™ anchors are fast and easy to install. A chamfer on the working end quickly centers the anchor and a high 30° helix angle allows it to be tightened quickly. The driving or hammering step required with typical anchors is eliminated.

Low installation torque

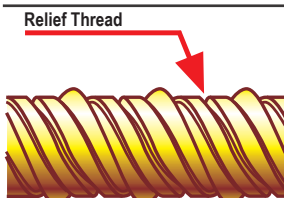

A specially designed relief thread formed in the body of the anchor allows easy tightening at a reduced torque level and generates a dust relief mechanism to prevent jamming of the anchor.

Double lead thread

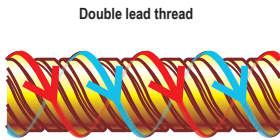

Blue -Tip SCREW-BOLT™ anchors are designed with a patented double lead, elliptical profile thread to facilitate easy centering, faster installation and higher load capacities.

Finished appearance - Won't spin in the hole

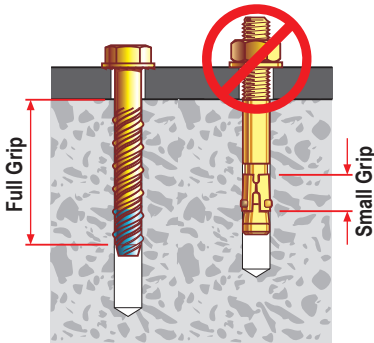

Blue -Tip SCREW-BOLT™ anchors have a finished hex washer head that provides an attractive appearance. They are safer than traditional mechanical anchors where exposed thread above the nut creates a tripping hazard.

Blue -Tip SCREW-BOLT™ anchors have specially designed dual threads that engage the base material immediately upon installation. Unlike traditional wedge or sleeve type anchors, they will not spin in the hole during installation

Easy to read length information



Blue -Tip SCREW-BOLT™ anchors have both the diameter and length clearly stamped on the head. Inspection is easy since there are no complicated letter codes to memorise.

Immediate high strength loading

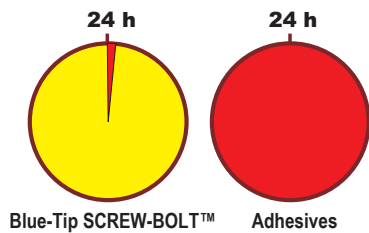

Blue -Tip SCREW-BOLT™ anchors can be loaded immediately, while still providing close to the edge performance. Unlike adhesive anchors, there is no lengthy curing time. This allows for immediate completion of fastening applications.

Removable and reusable

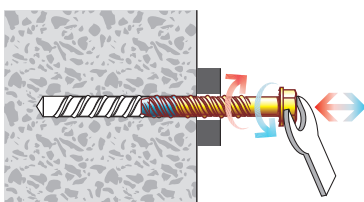

Blue -Tip SCREW-BOLT™ anchors are easy to remove, leaving a neat clean hole. Unlike traditional anchor types, no grinding off of anchors is necessary and anchor components are not left in the drilled hole to cause corrosion. If required, the Blue -Tip SCREW-BOLT™ can be reused in the same hole after rectification or adjustment of the fixing application

Vibration resistant

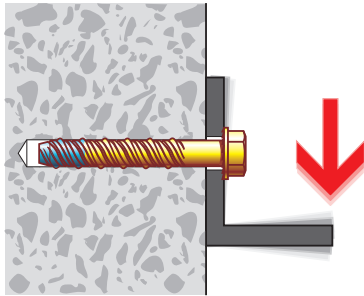

Blue -Tip SCREW-BOLT™ anchors are vibration resistant. Unlike traditional anchors that have a small expansion mechanism, the double lead threads grip the base material over the full embedment length and there are no expansion forces to pulverise the concrete. For additional vibration resistance, the ratchet teeth on the underside of the hex washer head lock against the fixture.

High strength - Cost effective

Comparison of Ultimate Tension Loads
20 mm dia. in 28 MPa concrete

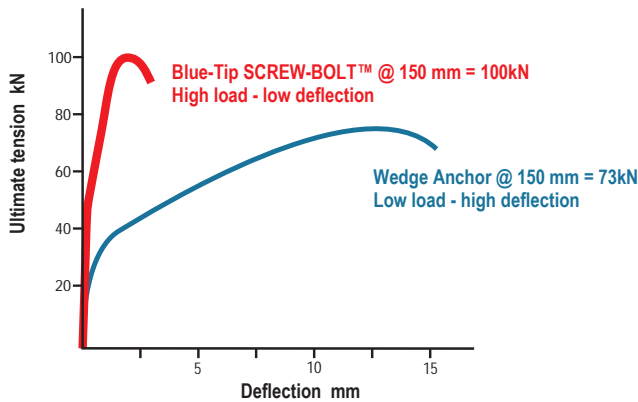

Blue -Tip SCREW-BOLT™ anchors are stronger than traditional wedge or sleeve types. They have the low slip and close edge characteristics of adhesive anchors. A combination of a patented dual lead thread and high strength steel material provide excellent performance. High tension loads often allow the Blue -Tip SCREW-BOLT™ to be used at a shallower embedment while high shear loads allow use of smaller diameters.

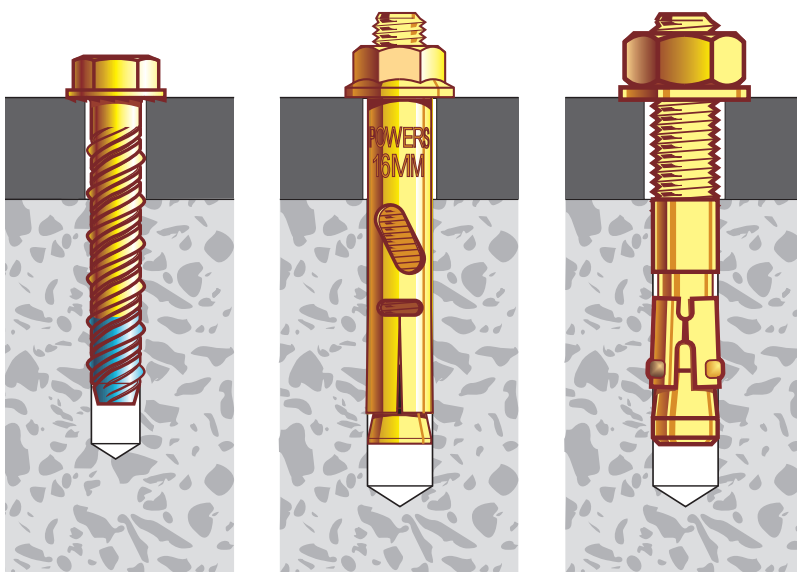
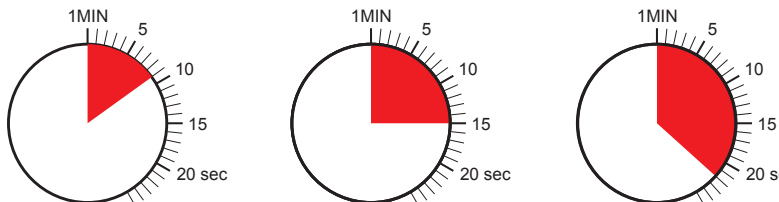

12mm Blue-Tip SCREW-BOLT™

16mm Sleeve Anchor

16mm Throughbolt

Blue -Tip SCREW-BOLT™ anchors save time and money. They are faster to install and easier to use. This helps to increase productivity while reducing worker fatigue. Installation time is decreased by up to 65%. For fast, easy, cost effective high performance installations, the innovative Blue -Tip SCREW-BOLT™ anchor is one product that does it all.

Installation procedures

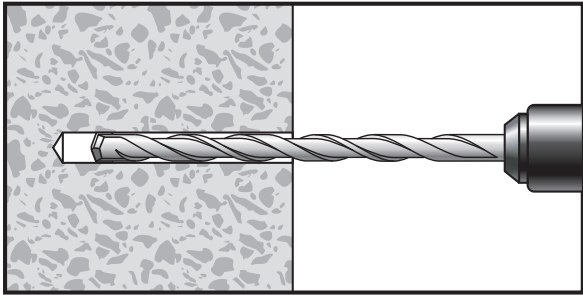

Using the proper diameter bit, drill a hole into the base material to a depth of at least one to two anchor diameters deeper than the embedment required.

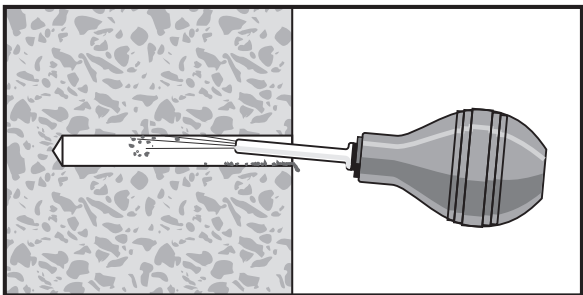

Blow the hole clean of dust and other material.

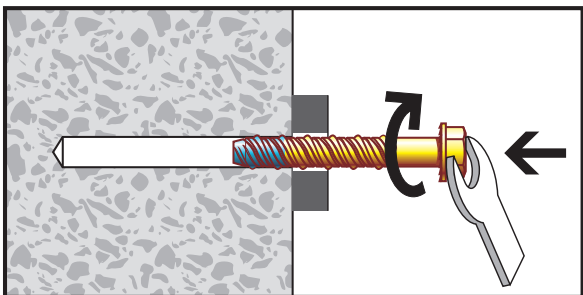

- Insert the anchor through the fixture into the anchor hole.
- Begin tightening the anchor by applying forward pressure when engaging the first thread.

Additional initial forward pressure may be required for installation in high strength, dense base materials.

- Continue tightening the anchor until the head is firmly seated against the fixture.
- In extremely dense materials, use of an impact wrench is recommended.
- Be sure the anchor is at the required embedment depth.
- Don't exceed the maximum clamping torque.
- The installation is now complete.

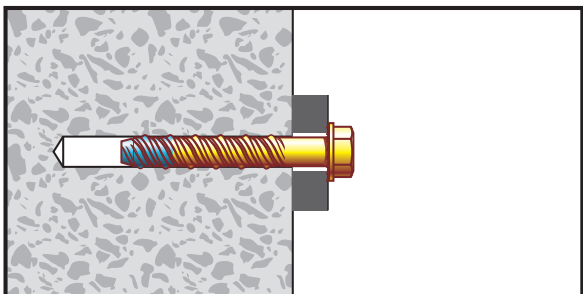

Installation tips:

- 1 Use quality hexagonal socket with a ratchet spanner.
- 2 Where substrate allows, a torque controlled impact wrench can be used.
- 3 During installation debris or dust created by the thread cutting action may cause some resistance to be experienced. This is easily overcome by unscrewing the Blue -Tip SCREW-BOLT™ for one turn, or more and then continue to fix to the full embedment.

Anchor sizes

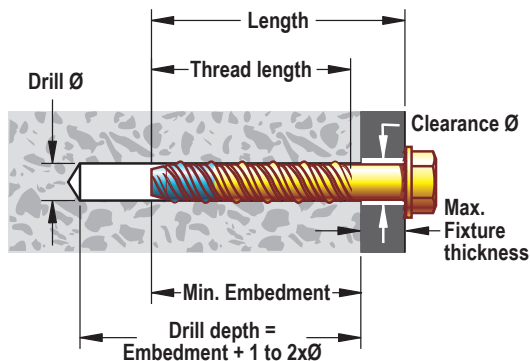

The following table lists the sizes of hex head Blue -Tip SCREW-BOLT™ anchors. To select the proper length; (1), determine the embedment depth required to obtain the desired load capacity (2), add the thickness of the fixture, (including any spacers or shims), to the embedment depth.

| Part No. | Article Number | Ø mm | Length mm | Thread Length mm | Minimum Embedment mm | Maximum Fixture Thickness mm | Clearance Hole Ø mm | Standard Box | Standard Carton |
|----------|----------------|------------|-----------|------------------|----------------------|------------------------------|---------------------|--------------|-----------------|
| BT550 | 27005 | 5 | 50 | 44.5 | 25 | 25 | 7 | 100 | 500 |
| BT6530 | 27010 | | 30 | 28.5 | | 5 | | 100 | 500 |
| BT6550 | 27015 | 6.5 | 50 | 44.5 | 25 | 25 | 8 | 100 | 500 |
| BT6575 | 27020 | | 75 | 70 | | 50 | | 50 | 250 |
| BT65100 | 27025 | | 100 | 95 | | 75 | | 50 | 250 |
| BT850 | 27030 | 8 | 50 | 44.5 | 35 | 15 | 10 | 50 | 250 |
| BT875 | 27035 | | 75 | 70 | | 40 | | 50 | 250 |
| BT8100 | 27040 | | 100 | 95 | | 65 | | 50 | 250 |
| BT1060 | 27045 | 10 | 60 | 54 | 40 | 20 | 12 | 50 | 250 |
| BT1075 | 27050 | | 75 | 70 | | 35 | | 50 | 250 |
| BT10100 | 27055 | | 100 | 95 | | 60 | | 50 | 250 |
| BT10120 | 27060 | | 120 | 95 | | 80 | | 50 | 250 |
| BT1275 | 27065 | 12 | 75 | 70 | 50 | 25 | 15 | 50 | 150 |
| BT12100 | 27070 | | 100 | 95 | | 50 | | 50 | 150 |
| BT12150 | 27075 | | 150 | 95 | | 100 | | 25 | 75 |
| BT16100 | 27080 | 16 | 100 | 95 | 65 | 35 | 19 | 15 | 60 |
| BT16150 | 27085 | | 150 | 95 | | 85 | | 15 | 60 |

Mechanical properties

| Mechanical properties | Units | 5 | 6.5 | 8 | 10 | 12 | 16 |
|-----------------------------------|-------------------|------|------|------|------|-------|-------|
| Nominal tensile strength f_u | N/mm ² | 1000 | 1000 | 1000 | 1000 | 1000 | 1000 |
| Yield strength f_y | N/mm ² | 900 | 900 | 900 | 900 | 900 | 900 |
| Stress cross sectional area A_s | mm ² | 11.1 | 21.1 | 38.5 | 60.7 | 82.7 | 153.8 |
| Section modulus Z | mm ³ | 5.2 | 13.7 | 33.5 | 66.6 | 106.1 | 269.1 |
| Nominal moment capacity M_f | N/m | 4.7 | 12.3 | 30.2 | 59.9 | 95.5 | 242.2 |

Comparison of anchor tensile strength

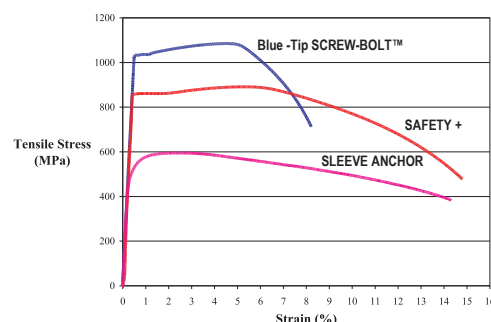

Blue -Tip SCREW-BOLT™ is manufactured using carbon steel that is heat treated to form a surface hardened high performance concrete anchor.

The heat treatment process ensures:

- a high strength and wear resistant surface providing easy, consistent and safe installation even in high compressive strength base materials
- increased core strength and toughness for impact and cyclic loading applications

Installation specifications

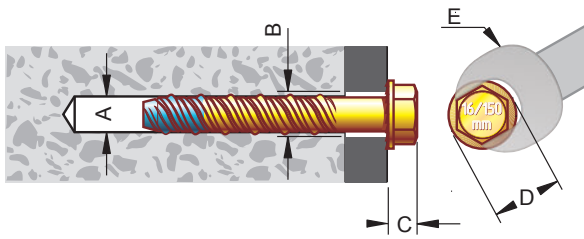

| A Anchor Ø mm | B Clearance Hole Ø mm | C Flanged Head Height mm | D Washer Ø mm | E Wrench size mm |
|---------------------|--------------------------------|-----------------------------------|---------------------|------------------------|
| 5 | 7 | 5 | 12 | 7 |
| 6.5 | 8 | 6 | 13 | 10 |
| 8 | 10 | 8 | 17 | 13 |
| 10 | 12 | 9.5 | 22 | 17 |
| 12 | 15 | 11.5 | 25 | 19 |
| 16 | 19 | 13.2 | 30 | 24 |

Maximum clamping torque (Nm)

| Base material | Anchor Ø | | | | | |
|--------------------|----------|-----|----|----|----|-----|
| | 5 | 6.5 | 8 | 10 | 12 | 16 |
| 15 MPa Concrete | 5 | 7 | 15 | 55 | 80 | 100 |
| 30 MPa Concrete | 8 | 15 | 45 | 55 | 80 | 100 |
| 40 MPa Concrete | 8 | 15 | 45 | 55 | 80 | 100 |
| Grout filled block | 8 | 15 | 15 | 20 | 55 | 80 |
| Solid red brick | 8 | 15 | 15 | 40 | 80 | 100 |

Blue -Tip SCREW-BOLT™ anchors achieve their load capacity by threads undercutting the base material. It is not necessary to tighten the anchor to any special torque value. The table to the left shows the maximum permissible torque value to be used to clamp the fixture to the base material.

Materials specifications

Blue -Tip SCREW-BOLT™ anchors are manufactured from heat treated carbon steel that is plated with commercial bright zinc, and a supplementary yellow chromate treatment in accordance with AS1789 and AS1791 Coating Designation C.

Anchor Specification:

| | |
|---------------------|---|
| Anchor body | AISI 1020 /1040 carbon steel (heat treated) |
| Zinc plating | 5 microns (minimum) |
| Mechanical plating* | 15 microns (minimum) |

* Mechanical plating provides equivalent corrosion resistance to Hot Dipped galvanising with 42 micron coating thickness in accordance with AS1214

Anchor Design Concepts

To provide flexibility for users of the Blue -Tip SCREW-BOLT™ manual, performance data in the manual has been presented in a way that allows quick and easy derivation of both Allowable Working Stress Design and Limit State Design Capacities.

Characteristic Ultimate Loads

Characteristic ultimate load capacities listed in this manual are based on actual anchor tests conducted in various base materials i.e. concrete, blockwork and brickwork. The characteristic ultimate load of an anchor is critical in defining the different anchor design concepts.

The characteristic ultimate load of an anchor is statistically defined as; 90% probability that 95% of actual test results fall above the characteristic ultimate load.

Characteristic Ultimate Load (N_A or V_A) = $X - kS$

Where: X = Mean ultimate load
S = Standard deviation of test results found by statistical analysis
k = Statistical confidence factor relating to sample size tested
 N_A = Characteristic Ultimate tension Load

Working Stress Design (International):

Allowable (Working) Load equals:

Characteristic Ultimate Load ÷ 3 (safety factor)

Limit State Design (Australian Standard AS3600-2001):

Design Anchor Capacity for Strength Limit State equals:

Characteristic Ultimate Load x 0.6 (strength reduction factor, ϕ)

Note: For further information on anchor design concepts please contact Powers Fasteners Technical department.

Performance data

Characteristic ultimate load capacities in concrete (kN)

| Anchor Ø mm | Embedment depth mm | 15 MPa Concrete | | 30 MPa Concrete | | 40 MPa Concrete | |
|-----------------------|------------------------------|--------------------|----------------|--------------------|----------------|--------------------|----------------|
| | | Tension N_A | Shear V_A | Tension N_A | Shear V_A | Tension N_A | Shear V_A |
| 5 | 25 | 1.8 | 2.5 | 2.6 | 5.0 | 3.1 | 5.9 |
| | 25 | 4.4 | 4.2 | 7.4 | 8.5 | 7.9 | 9.9 |
| 6.5 | 30 | 7.1 | 10.3 | 9.0 | 11.5 | 9.5 | 11.5 |
| | 45 | 9.9 | 11.2 | 15.0 | 11.9 | 17.6 | 13.5 |
| 8 | 35 | 8.9 | 10.6 | 12.1 | 14.3 | 13.0 | 18.9 |
| | 40 | 10.5 | 13.6 | 14.2 | 18.4 | 15.7 | 20.2 |
| | 60 | 17.8 | 19.1 | 22.1 | 19.1 | 29.2 | 20.2 |
| 10 | 40 | 11.8 | 14.6 | 14.7 | 19.7 | 16.7 | 29.7 |
| | 50 | 14.3 | 19.9 | 18.1 | 25.6 | 20.9 | 29.7 |
| | 75 | 22.1 | 24.9 | 28.5 | 26.2 | 35.3 | 29.7 |
| | 90 | 28.0 | 29.3 | 36.8 | 29.9 | 44.1 | 30.6 |
| 12 | 50 | 20.1 | 26.3 | 21.8 | 29.7 | 26.5 | 36.0 |
| | 60 | 21.4 | 29.9 | 27.7 | 34.3 | 31.8 | 36.9 |
| | 90 | 31.9 | 34.7 | 52.3 | 37.8 | 56.0 | 37.8 |
| | 110 | 32.2 | 34.7 | 58.4 | 38.7 | 61.6 | 38.7 |
| 16 | 65 | 20.4 | 31.5 | 28.0 | 45.7 | 33.9 | 54.9 |
| | 75 | 24.6 | 40.6 | 32.9 | 51.3 | 39.1 | 57.6 |
| | 100 | 39.1 | 54.9 | 52.2 | 61.6 | 60.6 | 63.7 |
| | 125 | 52.4 | 66.0 | 70.4 | 71.1 | 81.3 | 71.1 |



Note:
Performance data is based on tests conducted in un-reinforced concrete of specified cylinder compressive strength.

Performance data

Characteristic ultimate load capacities for grout filled block (kN)

| Anchor Ø mm | Embedment depth mm | Tension N_A | Shear V_A |
|----------------|-----------------------|------------------|----------------|
| 5 | 30 | 1.5 | 2.4 |
| 6.5 | 65 | 8.6 | 5.6 |
| 8 | 80 | 9.7 | 9.2 |
| 10 | 90 | 12.8 | 14.5 |
| 12 | 100 | 18.2 | 26.7 |
| 16 | 100 | 23.1 | 42.5 |

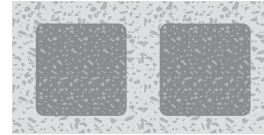

400 x 200 x 200mm block
Manufacturer: NUBRIK
Block compressive strength: 12MPa
Grout compressive strength: 20MPa

Characteristic ultimate load capacities for solid pressed red brick (kN)

| Anchor Ø mm | Embedment depth mm | Tension N_A | Shear V_A |
|----------------|-----------------------|------------------|----------------|
| 5 | 35 | 9.2 | 5.1 |
| 6.5 | 40 | 13.7 | 6.6 |
| 8 | 50 | 19.6 | 12.5 |
| 10 | 60 | 23.1 | 17.2 |
| 12 | 75 | 33.6 | 31.6 |
| 16 | 80 | 40.0 | 48.4 |

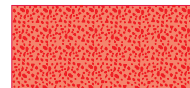

230 x 110 x 76mm
Manufacturer: NUBRIK
Brick compressive strength: 40MPa

Characteristic ultimate load capacities for 10 hole extruded wire cut brick (kN)

| Anchor Ø mm | Embedment depth mm | Tension N_A | Shear V_A |
|----------------|-----------------------|------------------|----------------|
| 5 | 25 | 0.8 | 1.7 |
| 6.5 | 65 | 2.1 | 3.9 |
| 8 | 65 | 3.0 | 6.4 |
| 10 | 65 | 3.1 | 9.9 |

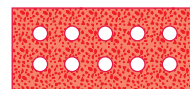

230 x 110 x 76mm
Manufacturer: BORAL
Brick compressive strength: 15MPa

Characteristic ultimate load capacities for 3 hole extruded wire cut brick (kN)

| Anchor Ø mm | Embedment depth mm | Tension N_A | Shear V_A |
|----------------|-----------------------|------------------|----------------|
| 5 | 40 | 7.4 | 5.4 |
| 6.5 | | 17.1 | 6.7 |
| 8 | | 19.6 | 11.4 |
| 10 | | 23.4 | 16.7 |
| 12 | | 26.2 | 27.5 |

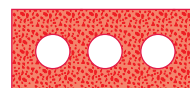

230 x 110 x 76mm
Manufacturer: BORAL
Brick compressive strength: ≥55MPa

Note: The consistency of brick and block walls varies greatly. Load capacities listed above are based on actual tests conducted in brick and block walls with M3 specification mortar (1 : 1 : 6, AS3700)
Capacities should be used as guidance only.

Combined loading

Anchors loaded in both tension and shear must satisfy the following equations:

Working stress design

$$\left(\frac{T_S}{T_A}\right)^{5/3} + \left(\frac{S_S}{S_A}\right)^{5/3} \leq 1$$

Where:

T_S = Applied Tension Load
 T_A = Allowable Tension Load
 S_S = Applied Shear Load
 S_A = Allowable Shear Load

Limit state design

$$\left(\frac{N^*}{\phi N_A}\right)^{5/3} + \left(\frac{V^*}{\phi V_A}\right)^{5/3} \leq 1$$

Where:

N^* = Design Tension Force
 ϕN_A = Design Tension Anchor Capacity
 V^* = Design Shear Force
 ϕV_A = Design Shear Anchor Capacity

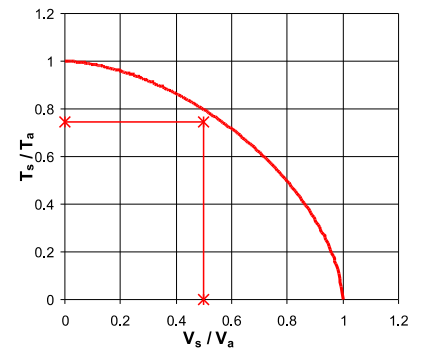

Design criteria - Concrete

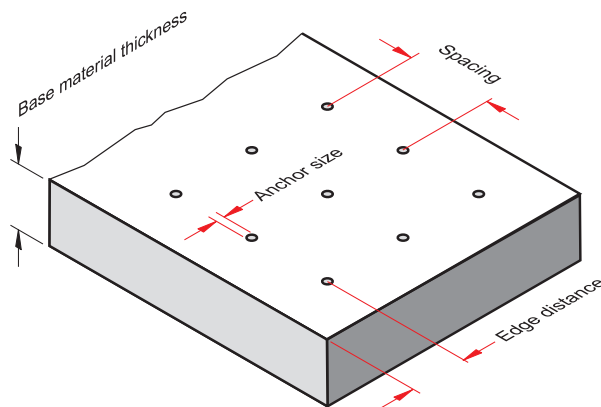

Base material thickness

The minimum recommended thickness of solid base material, BMT, is 125% of the embedment to be used. For example, when installing an anchor to a depth of 100mm, the base material thickness should be 125mm.

Spacing between anchors

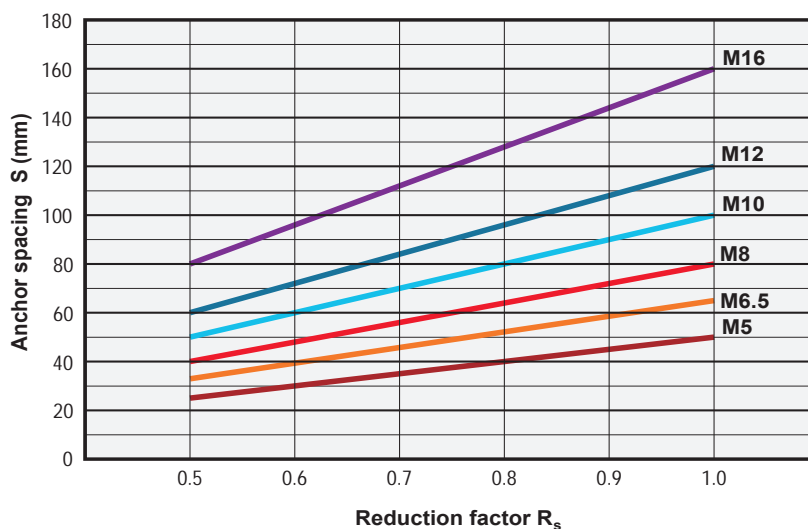

To obtain the maximum load in tension or shear, a spacing, S , of 10 anchor diameters ($10d$) should be used. The minimum recommended anchor spacing, S , is 5 anchor diameters ($5d$) at which point the load should be reduced by 50%. The graph shows the load reduction factor, R_s , for each anchor diameter, based on the center to center anchor spacing.

Edge distance - Tension

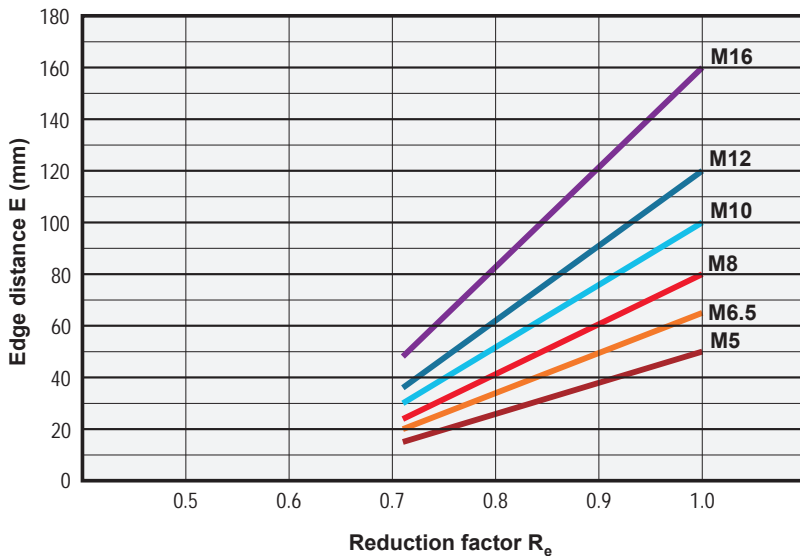

An edge distance, E, of 10 anchor diameters (10d) should be used to obtain the maximum tension load. The minimum recommended edge distance, E, is 3 anchor diameters (3d) at which point the tension load should be reduced by 28%. The graph shows the load reduction factor, R_e , for each anchor diameter, based on the anchor center to edge distance.

Edge distance - Shear

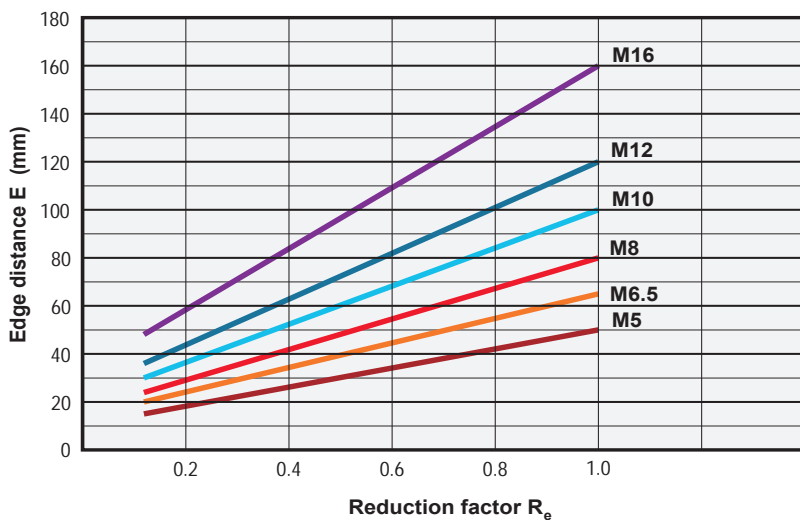

For shear, an edge distance, E, of 10 anchor diameters (10d) should be used to obtain the maximum shear load. The minimum recommended edge distance, E, is 3 anchor diameters (3d) at which point the shear load should be reduced by 84%. The graph shows the load reduction factor, R_e , for each anchor diameter, d, based on the anchor center to edge distance.

Design criteria - Masonry (Brick and Blockwork)

- When fixing into brickwork or blockwork, position anchors a minimum of 300mm from an edge or opening.
- Anchors should be positioned four brick & 2 block courses down from the top of an unrestrained wall
- Minimum recommended spacing between anchors is 200mm
- Embedment should be limited to within 30mm of the remote face of the block / brick
- Avoid fixing into mortar joints

Anchors for use in Seismic / Cyclic Applications

Chart 1

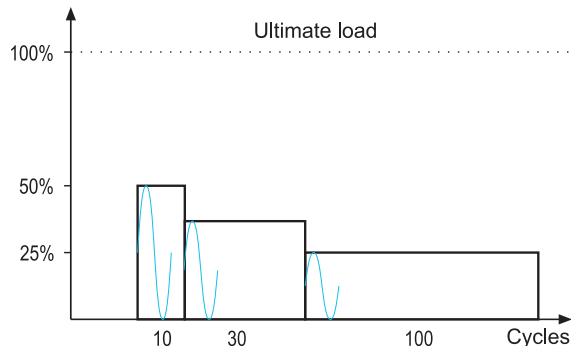

The selection and suitability of anchoring systems for seismic applications should be determined by a design professional in accordance with relevant building codes and standards. To assist in selecting the correct anchoring system, Powers Fasteners have conducted independent seismic tests on the Blue -Tip SCREW-BOLT™ anchor highlighting its suitability.

Chart 2

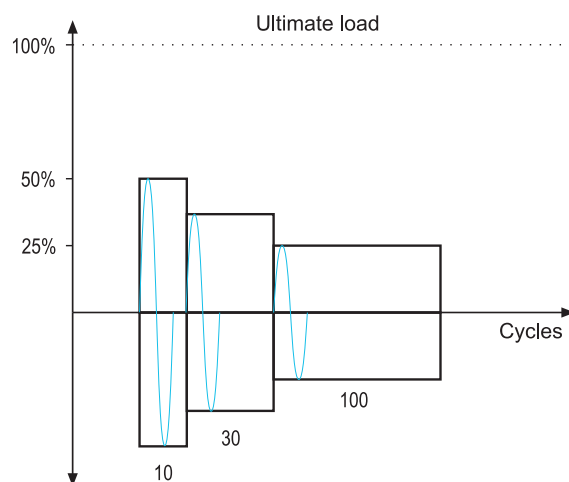

Earthquakes can induce loads in anchoring systems well in excess of their allowable working load levels. Evaluating the suitability of the Blue -Tip SCREW-BOLT™ involved subjecting the anchor to a simulated seismic test program in accordance with ICBO Evaluation Services Inc. (USA Standard). Load cycles are shown in Chart 1 and 2 (Frequency 1Hz). Load was applied sinusoidally between a load no greater than 5% of the ultimate load and the required cyclic load level.

Chart 3

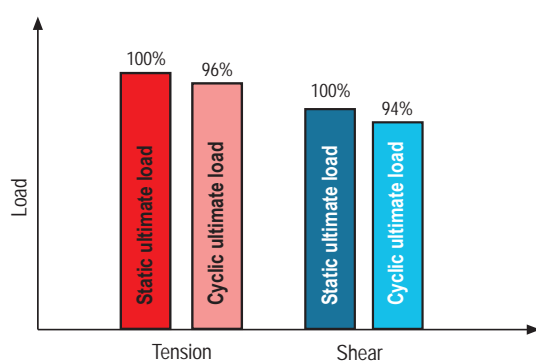

Blue -Tip SCREW-BOLT™

Acceptance criteria in accordance with ICBO Evaluation Services Inc. AC01 (USA Standard) is as follows:

- **Anchor must withstand the loading cycles without failure**
- **Anchor must be able to attain at least 80% of the static ultimate tension or shear capacity**
- **Blue -Tip SCREW-BOLT™ passed both criteria, refer chart 3.**

Product Specification Writing

Powers Fasteners Blue -Tip SCREW-BOLT™ (Product Part No.) @ (Anchor Embedment Depth) Installation in accordance with Powers installation instructions.

Example: Powers Fasteners Blue -Tip SCREW-BOLT™ BT12150 @ 110mm embedment (minimum). Installation in accordance with Powers Installation Instructions.

Notes:

Powers' range of technical literature

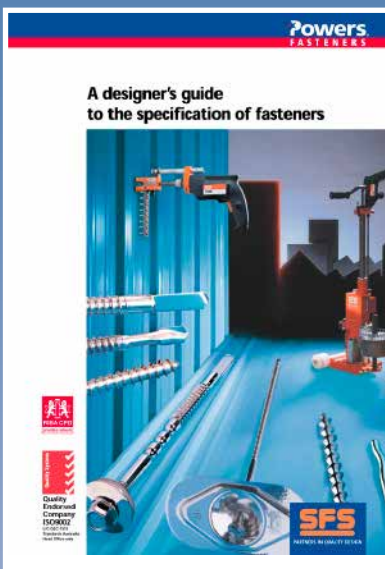
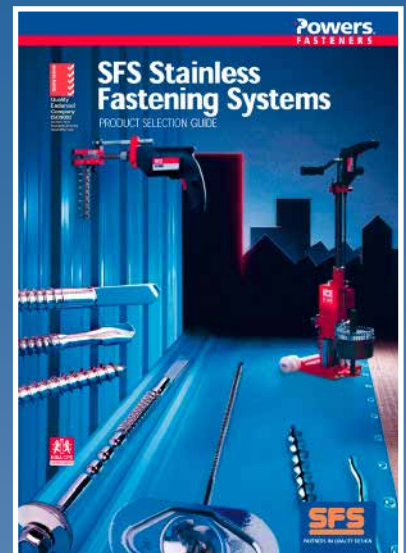
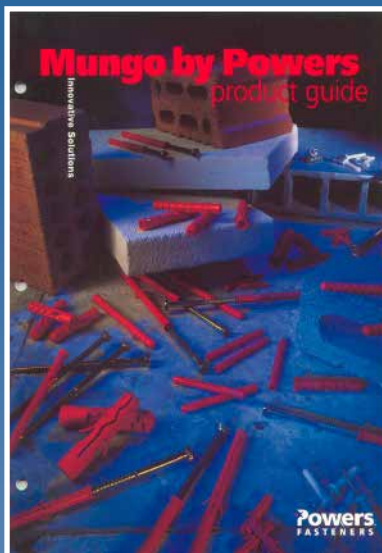
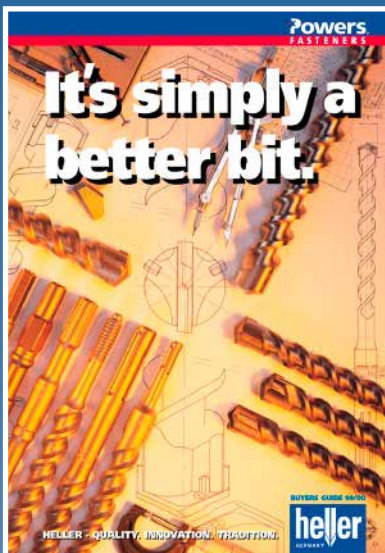
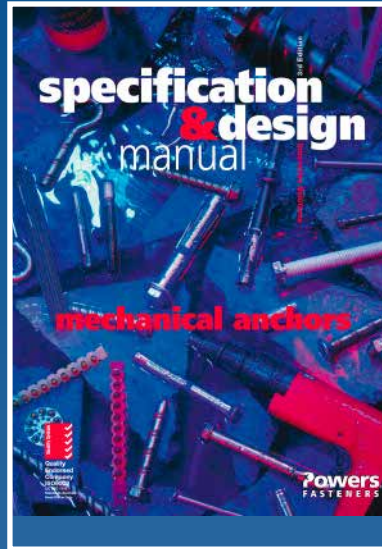
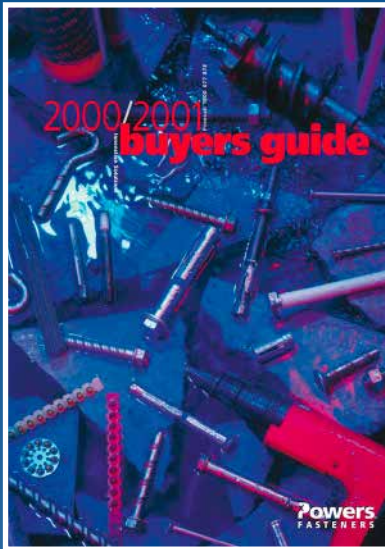



Distributor:

Aerofast Australia Pty Ltd
ABN: 23 068 361 455
LOGAN CITY
8 Booran Drive, Woodridge QLD 4114
Tel: 07 3299 4555 Fax: 07 3299 4566
email: sales@aerofast.com.au
GOLD COAST
Unit 1/13 John Duncan Court
Varsity Lakes QLD 4227
Tel: 07 5593 4550 Fax: 07 5593 4549
email: coastsales@aerofast.com.au
WEB: www.aerofast.com.au

MELBOURNE (Head Office):

TELEPHONE: 03-9553 3999
FACSIMILE: 03-9553 4400

SYDNEY:

TELEPHONE: 02-9748 7766
FACSIMILE: 02-9648 5977

BRISBANE:

TELEPHONE: 07-3216 7122
FACSIMILE: 07-3216 7216

PERTH:

TELEPHONE: 1800 677 872
FACSIMILE: 03-9553 4400

ADELAIDE:

TELEPHONE: 0439 083 650
FACSIMILE: 08-8388 1253

HOBART:

TELEPHONE: 03-6273 5800
FACSIMILE: 03-6273 4977

AUCKLAND (NEW ZEALAND):

TELEPHONE: 64-9415 2425
FACSIMILE: 64-9415 2627

Quality System



**Quality
Endorsed
Company
ISO9002**

LIC QEC 7312
Standards Australia
Head Office Only